

DIGITAL PA AMPLIFIERS

A-2030D/ DD SERIES

A-2060D/ DD SERIES

A-2120D/ DD/ DT SERIES

A-2240D/ DD/ DT SERIES

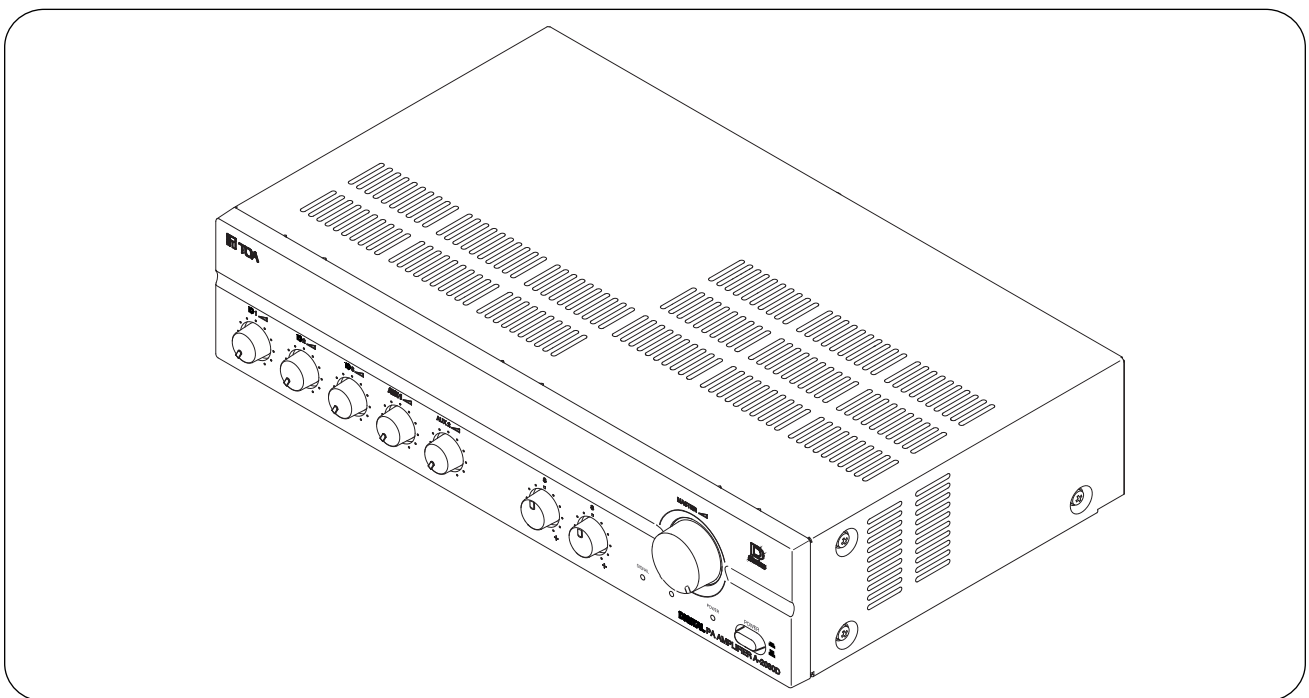

TABLE OF CONTENTS

1. SAFETY PRECAUTIONS	2	6.2. Output Connection	7
2. GENERAL DESCRIPTION	3	6.3. Tones Connection (A-2000DT-AS SERIES)	7
3. FEATURES	3	6.4. Example of External Equipment Connections	7
4. NOMENCLATURES AND FUNCTIONS		7. VOLUME CONTROL SETTING	8
4.1. Front	4	8. BLOCK AND LEVEL DIAGRAMS	8
4.2. Rear	4	9. DIMENSIONAL DIAGRAM	10
5. MUTING FUNCTION	6	10. SPECIFICATIONS	10
6. CONNECTIONS			
6.1. Input Connections	6		

Thank you for purchasing TOA's Digital PA Amplifiers.
Please carefully follow the instructions in this manual to ensure long, trouble-free use of your equipment.

1. SAFETY PRECAUTIONS

- Before installation or use, be sure to carefully read all the instructions in this section for correct and safe operation.
- Be sure to follow all the precautionary instructions in this section, which contain important warnings and/or cautions regarding safety.
- After reading, keep this manual handy for future reference.

Safety Symbol and Message Conventions

Safety symbols and messages described below are used in this manual to prevent bodily injury and property damage which could result from mishandling. Before operating your product, read this manual first and understand the safety symbols and messages so you are thoroughly aware of the potential safety hazards.



WARNING

Indicates a potentially hazardous situation which, if mishandled, could result in death or serious personal injury.



CAUTION

Indicates a potentially hazardous situation which, if mishandled, could result in moderate or minor personal injury, and/or property damage.



WARNING

- Apparatet må tilkoples jordet stikkontakt.
- Apparaten skall anslutas till jordat uttag.

When Installing The Unit

- Do not expose the unit to rain or an environment where it may be splashed by water or other liquids, as doing so may result in fire or electric shock.
- Use the unit only with the voltage specified on the unit. Using a voltage higher than that which is specified may result in fire or electric shock.
- Do not cut, kink, otherwise damage nor modify the power supply cord. In addition, avoid using the power cord in close proximity to heaters, and never place heavy objects including the unit itself on the power cord, as doing so may result in fire or electric shock.
- The terminals marked with the symbol  are hazardous live. The external wiring to these terminals requires installation by an instructed person.
- The socket-outlet shall be installed near the equipment and the plug (disconnecting device) shall be easily accessible.
- Be sure to replace the unit's terminal cover after connection completion. Because the voltage of up to 100V is applied to the high impedance speaker terminals, never touch these terminals to avoid electric shock.
- Be sure to ground to the safety ground (earth) terminal to avoid electric shock. Never ground to a gas pipe as a catastrophic disaster may result.
- Apparatets stikprop skal tilsluttes en stikkontakt med jord, som giver forbindelse til stikproppens jord.
- Laite on liitettävä suojakoskettimilla varustettuun pistorasiaan.

When The Unit is in Use

- Should the following irregularity be found during use, immediately switch off the power, disconnect the power supply plug from the AC outlet and contact your nearest TOA dealer. Make no further attempt to operate the unit in this condition as this may cause fire or electric shock.
 - If you detect smoke or a strange smell coming from the unit.
 - If water or any metallic object gets into the unit.
 - If the unit falls, or the unit case breaks.
 - If the power supply cord is damaged (exposure of the core, disconnection, etc).
 - If it is malfunctioning (no tone sounds).
- To prevent a fire or electric shock, never open nor remove the unit case as there are high voltage components inside the unit. Refer all servicing to your nearest TOA dealer.
- Do not place cups, bowls, or other containers of liquid or metallic objects on top of the unit. If they accidentally spill into the unit, this may cause a fire or electric shock.
- Do not insert nor drop metallic object or flammable materials in the ventilation slots of the unit's cover, as this may result in fire or electric shock.
- Class I construction shall be connected to a main socket outlet with a protective earthing connection.
- The ventilation should not be impeded by covering the ventilation openings with items, such as newspapers table-cloths, curtains, etc.
- No naked flames source such as lighted candles, should be placed on the apparatus.
- The use of apparatus in moderate climates.

CAUTION

When Installing The Unit

- Never plug in nor remove the power supply plug with wet hands, as doing so may cause electric shock.
- When unplugging the power supply cord, be sure to grasp the power supply plug, never pull on the cord it self. Operating the unit with a damaged power supply cord may cause a fire or electric shock.
- When moving the unit, be sure to remove its power supply cord from the wall outlet. Moving the unit with the power cord connected to the outlet may cause damage to the power cord, resulting in fire or electric shock. When removing the power cord, be sure to hold its plug to pull.
- Do not block the ventilation slots in the unit's cover. Doing so may cause heat to build up inside the unit and result in fire. Also periodically clean the ventilation slots of dust.
- Avoid installing the unit in humid or dusty location, in location exposed to direct sunlight, near the heaters, or in location generating sooty smoke or steam as doing otherwise may result in fire or electric shock.
- To avoid electric shocks, be sure to switch off the unit's power when connecting speaker.
- Be sure to follow the instructions below when rack mounting the unit. Failure to do so may cause a fire of personal injury.
 - Install the equipment rack on a stable, hard floor. Fix it with anchor bolts or take other arrangements to prevent it from falling down.
 - When connect the unit's power cord to an AC outlet, use the AC outlet with current capacity allowable to the unit.
 - Rack-mounting screws are not supplied with the unit. Prepare them that are appropriate for the equipment rack.

2. GENERAL DESCRIPTION

TOA's Digital PA Amplifiers A-2030D, A-2060D, A-2120D, A-2120DT and A-2240D, A-2240DT Series are high performance mixer power amplifier suited for broadcasting paging or background music in schools, offices, shop, factories, mosque, churches and large room.

3. FEATURES

- High durability, high reliability and high performance.
- Three microphone inputs are electronically-balanced input, two AUX input and one recording output.
- MIC 1 with phantom power for condenser microphone.
- Speaker output of constant voltage distribution system (100V).
- Operates on AC power.
- Muting function.
- Independent input volume control and master volume control.
- Independent tone control of boost and cut type for both high and low frequency.
- Current limiter circuitry protects transistor and thermal protection circuitry prevent a failure due to overheat.

- Keep the distance for all side of units 10 cm away from the object that may obstruct air flow for internal units temperature rise prevention.

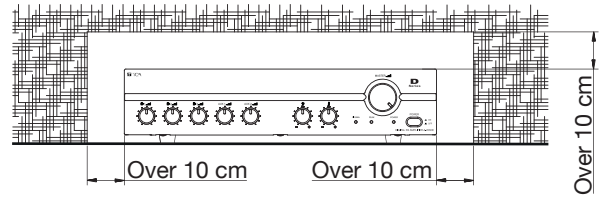

When The Unit is In Use

- Do not place heavy object on the unit as this may cause it to fall or break which may result in personal injury and/or property damage. In addition, the object it self may fall of and cause injury and/or damage.
- Make sure that the volume control is set to minimum position before power is switched on, Loud noise produced at high volume when is power is switched on can impair hearing.
- Switch OFF the unit's power before turning the phantom power switch ON or OFF. Operating the switch without switching OFF the main power could resulting a large transient noise thought the speakers, potentially resulting in speaker failure.
- Avoid using phantom power when connecting an unbalanced microphone to the MIC 1 input, as the microphone fails.
- Do not operate the unit for an extended period of time with the sound distorting. Doing so may cause the connected speakers to heat, resulting in a fire.
- Contact your TOA dealer as to the cleaning. If dust is allowed to accumulate in the unit over a long period of time, a fire or damage to the unit may result.
- If dust accumulates on the power supply plug or in the wall AC outlet, a fire may result. Clean it periodically. In addition, insert the plug in the wall outlet securely.
- Switch off the power, and unplug the power supply plug from the AC outlet for safety purposes when cleaning or leaving the unit unused for 10 days or more. Doing otherwise may cause a fire or electric shock.

4. NOMENCLATURES AND FUNCTIONS

4.1. Front

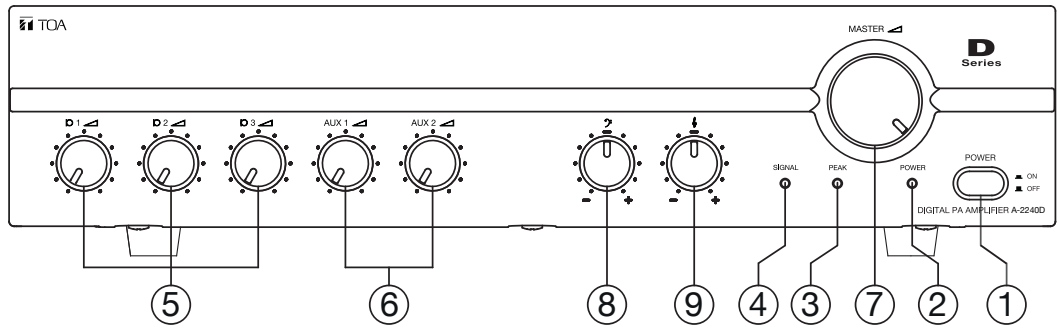

4.2. Rear

[A-2000D-AS 2CE Series]

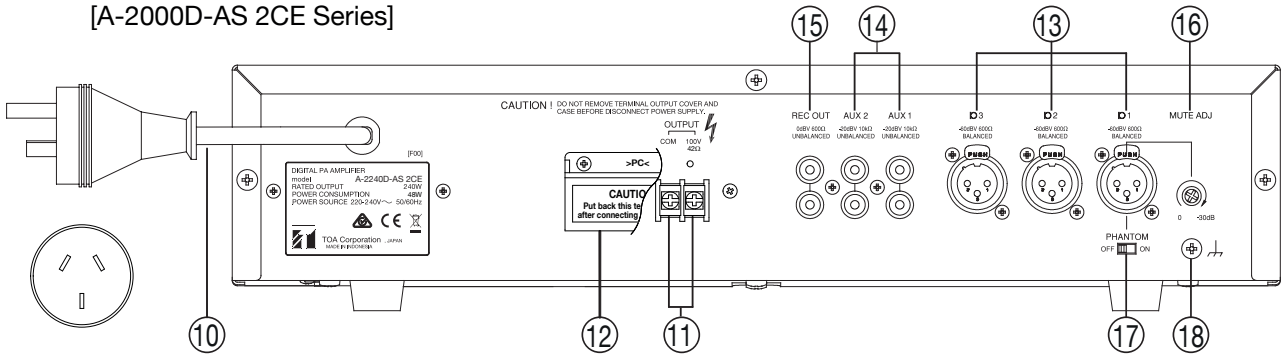

[A-2000DT-AS 2CE Series]

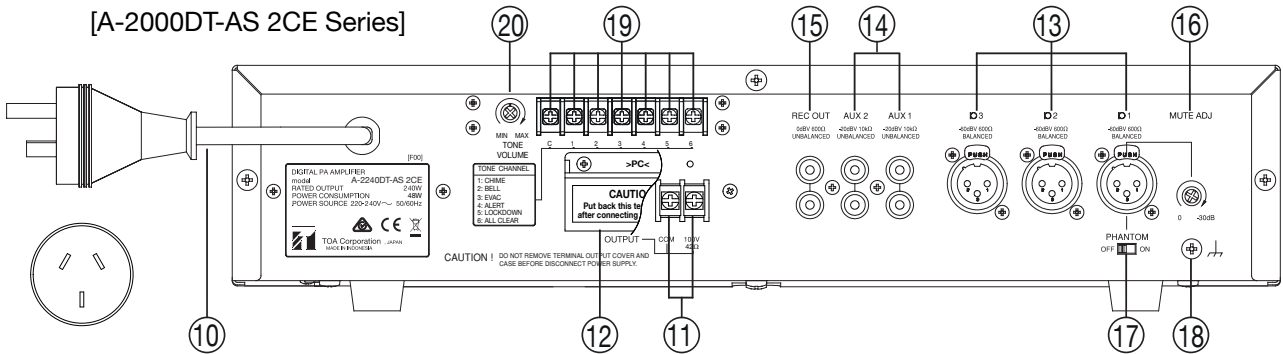

[A-2000D-EA 4CE Series]

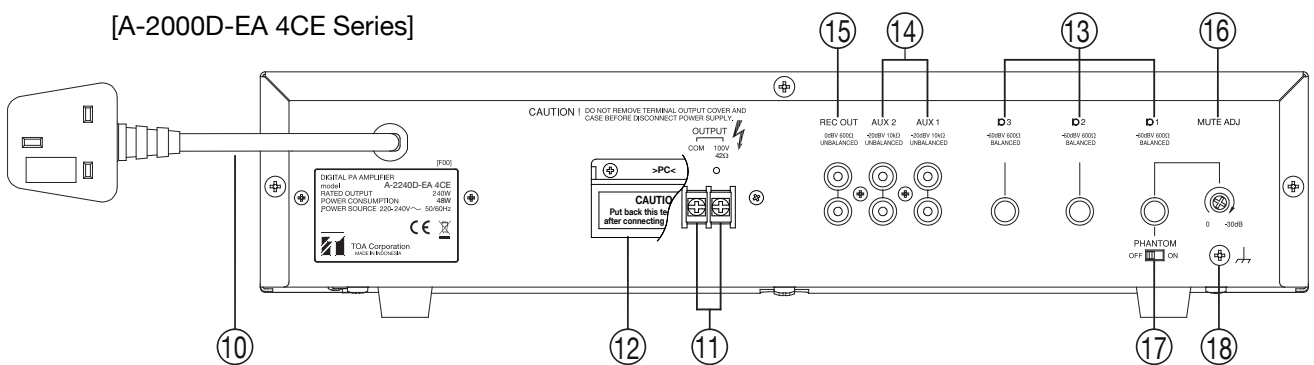

[A-2000D-EB 1CE Series]

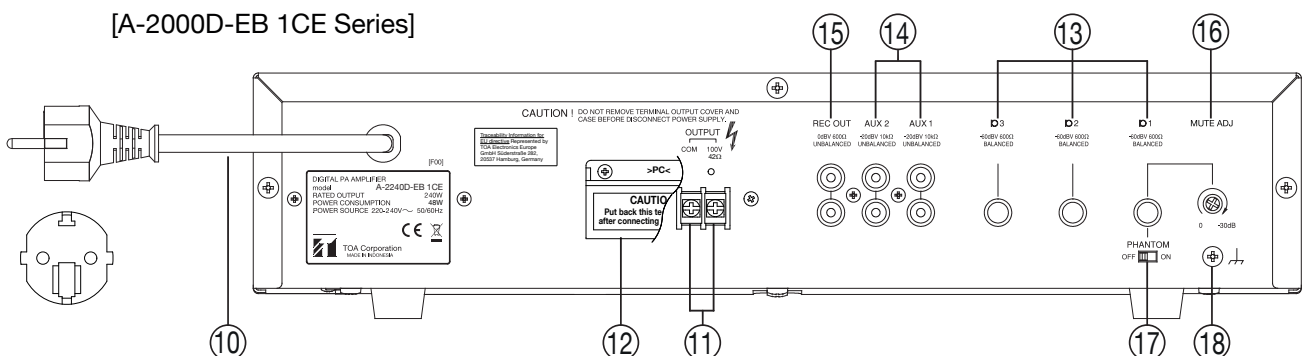

[A-2000D-EB 4CE Series]

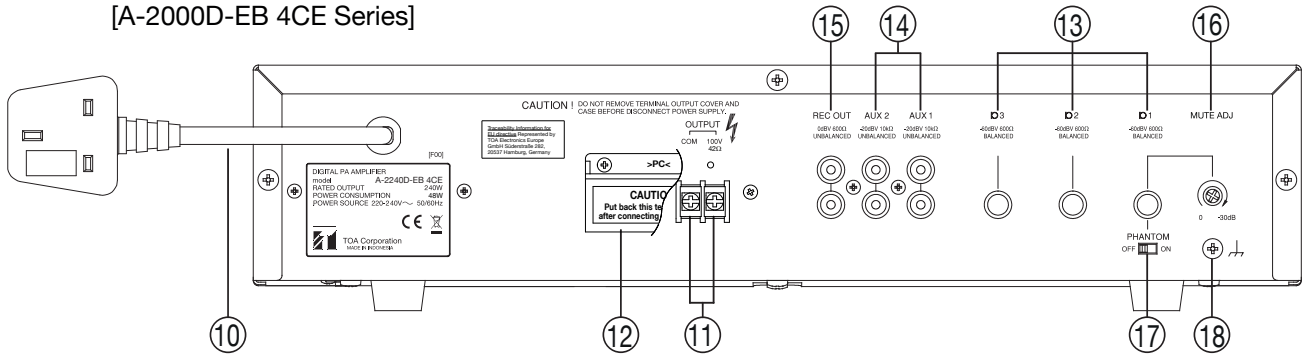

[A-2000DD-EB 1CE Series]

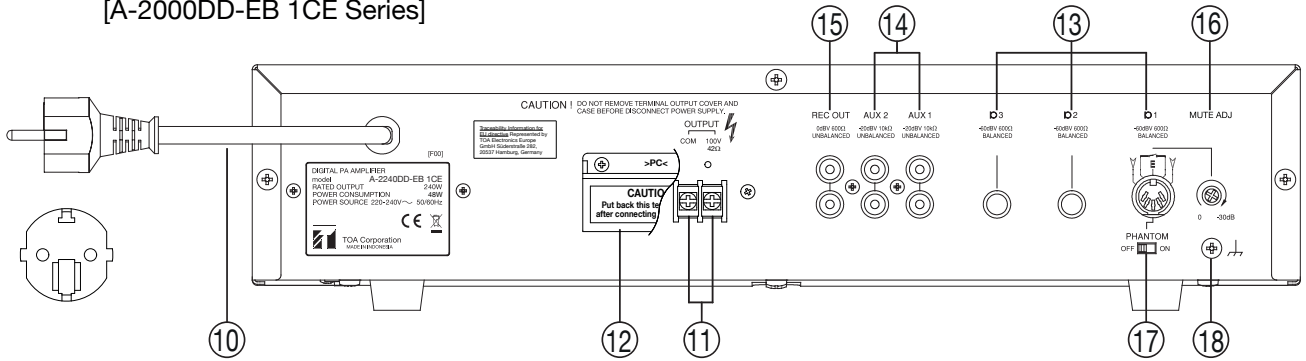

[A-2000DD-EB 4CE Series]

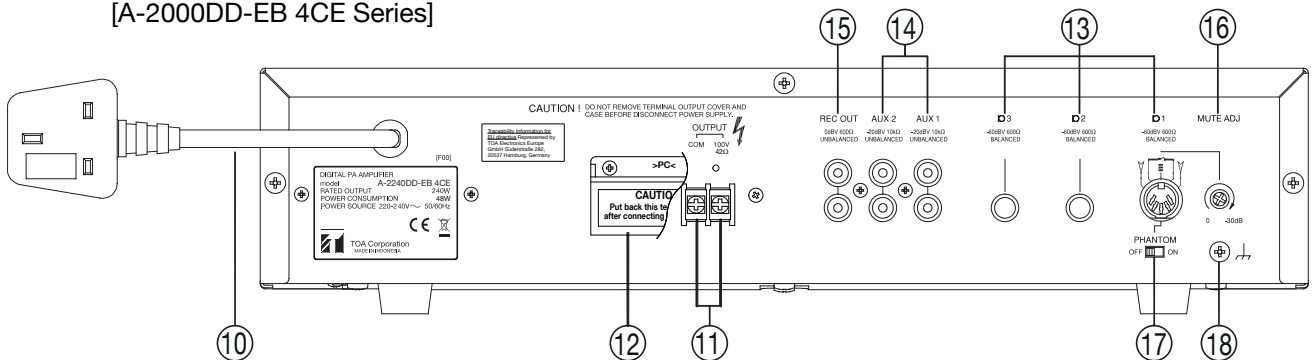

1. Power Switch

Press to turn ON the power. Press again to turn off the power.

2. Power Indicator

Lights green when power is switched ON.

3. Peak Indicator

Lights red to indicate the output signal reaches the peak level, this indicates that sound is distorted. In such case, adjust each volume control to reduce output level.

4. Signal Indicator

Lights green for indicates present of an output signal.

5. Microphone Volume Control

Adjust the microphone level.

6. AUX Volume Control

Adjust the AUX level.

7. Master Volume Control

Adjust overall signal level.

8. Bass Control

Adjust bass response. Rotate clockwise to increase bass output and counter clockwise to reduce it. The center position provide flat characteristic.

9. Treble Control

Adjust treble response. Rotate clockwise to increase treble output and counter clockwise to reduce it. The center position provide flat characteristic.

10. AC Power Cord

Connect to an AC power source.

11. Output Terminal

Terminal for connecting speaker. Use only with high impedance speaker.

12. Terminal Cover

To avoid electric shock by high voltage from output terminal, put back terminal cover after connecting speaker cords.

13. MIC 1, MIC 2, and MIC 3

-60dB (1mV), 600Ω, electronically balanced.

Mic 1 provides phantom it can applied to condenser microphone.

note:

XLR connection: Pin-1 Ground, Pin-2 Hot, Pin-3 Cold.

5-pin DIN connection: Pin-1 Hot, Pin-2 Ground, Pin-3 Cold, Pin-4 and Pin-5 mute switch. When pin-4 is shorted with pin-5, the muting function is Ground operated.

Phone plug connection, can used double pole type, and single pole type.
 MIC 1 input can operate a dynamic microphone with phantom power position OFF. And condenser microphone with phantom power position ON.
 MIC 2, MIC 3 input can operate a dynamic microphone.

14. AUX 1 & AUX 2 Input Terminal
 -20dB, 10kΩ, unbalanced. Monaural RCA pin jack. Accept external equipment output signal.

15. Recording Output
 0dB (1V), 600Ω, unbalanced. Output all input signal before the master volume control. Connect to a cassette deck, etc., when recording the broadcast content.

16. Muting Level Control
 Adjust attenuating level from 0 to -30dB.
 Factory preset : -30dB (maximum muting level).

17. Phantom Switch
 Selecting to ON position supplies power for condenser microphone from MIC 1. Be sure to select OFF when using the microphone that can not operated on phantom power. The phantom power is 21 V DC. Factory preset : OFF.

18. Ground Terminal
 Connect to ground (earth) to avoid electric shock.

19. Tones Option (for A-2000DT-AS 2CE Series only)
 6 tones contact trigger (Chime, Bell, Evac, Alert, Lockdown, All Clear).

20. Tone Volume Level Control (A-2000DT-AS 2CE Series only)
 Adjust attenuating level from MIN to MAX.
 Factory preset : middle (center level).

5. MUTING FUNCTION

MIC 1 has a priority function. When MIC 1 input is used it take precedence and automatically attenuate the volume of MIC 2, MIC 3, AUX 1 & AUX 2 inputs by 0 up to 30dB, which is adjustable with the MUTE ADJ on rear panel. The attenuation level is preset for -30dB at the factory.

Remark : About mute function

- When signal of MIC 1 appear, mute circuit work promptly.
- When signal of MIC 1 disappear, it returns to it previous state about 3 seconds later.



A-2000DD-EB Series only

Shorting DIN plug pin-4 and pin-5 of rear mounted Mic 1 input allow Mic 1 input to reduce the volume of Mic 2, Mic 3, Aux 1, and Aux 2 inputs by 0 to -30dB. The attenuation level is preset for -30dB at factory. We recommended using TOA's microphone PM-222D or PM-660D to bring the best results.

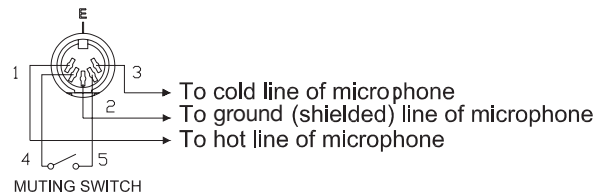

6. CONNECTIONS

6.1. Input Connections

- MIC 1, MIC 2, MIC 3 Connection (Phone Plug)

Because MIC input is electronically balanced type, it uses double pole phone plug.

Double Pole Phone Plug

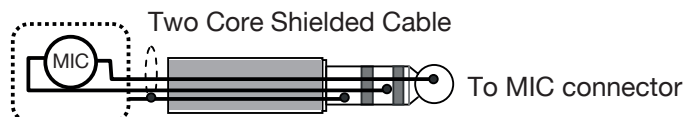

However, the microphone input circuit is in a condition of unbalance when using single pole type. Since the state of unbalance is more vulnerable for noise generation, the recommended length of microphone cable is at less than 10m.

Single Pole Phone Plug

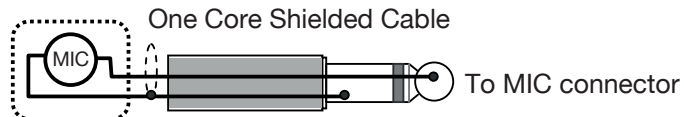

- MIC 1, MIC 2, MIC 3 Connection (XLR Plug)



1= ground/shield
 2= hot (+ve)
 3= cold (-ve)

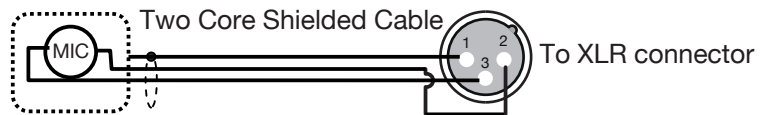

for unbalanced use, pin 1 and pin 3 have to bridged

- AUX Input Connection (RCA Pin Jack)

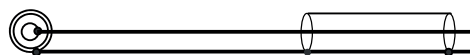

Signal source (Tuner, Cassette Tape, etc)

One Core Shielded

Please use commercial RCA cables to wire the 2-track input and output.

• MIC1 Connection (5-pin DIN Plug)

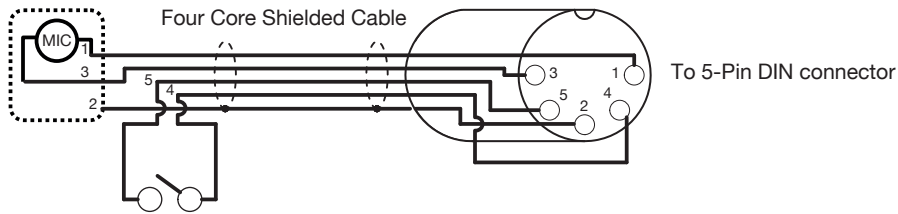

6.2. Output Connection

Total impedance for 100V line :

- 330Ω (A-2030D Series)
- 170Ω (A-2060D Series)
- 83Ω (A-2120D Series)
- 42Ω (A-2240D Series)

CAUTION !

Impedances indicate at the terminal represent the total impedance (load) of the speaker system.

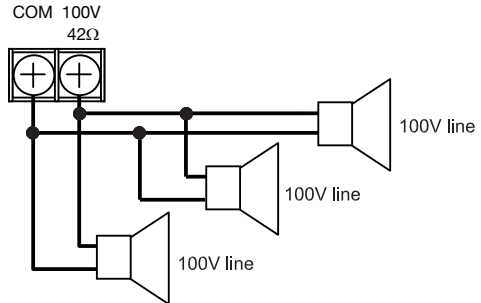

⚠ CAUTION
 Be sure to attach the supplies terminal cover after connection completion.
 Since high voltage is applied to the speaker terminal, never touch these terminals to avoid electric shock.

6.3. Tones Connection (for A-2000DT-AS 2CE Series only)

- Tones connection just operation at one connection for one time.
- Connection 1 to C will function sound Chime.
- Connection 2 to C will function sound Bell.
- Connection 3 to C will function sound Evacuation.
- Connection 4 to C will function sound Alert.
- Connection 5 to C will function sound Lockdown.
- Connection 6 to C will function sound All Clear.

Note : Priority at tone function

- When signal of tone appear, mute circuit work promptly.
- When signal of tone disappear, it returns to it previous state.

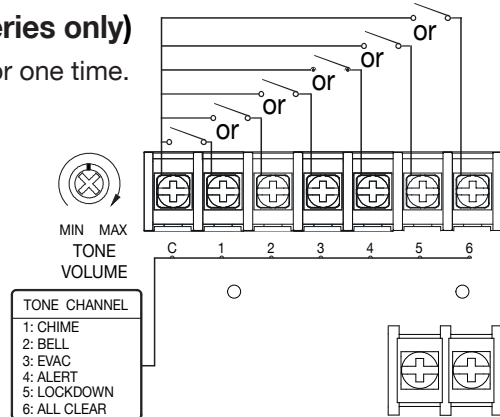

6.4. Example of External Equipment Connections

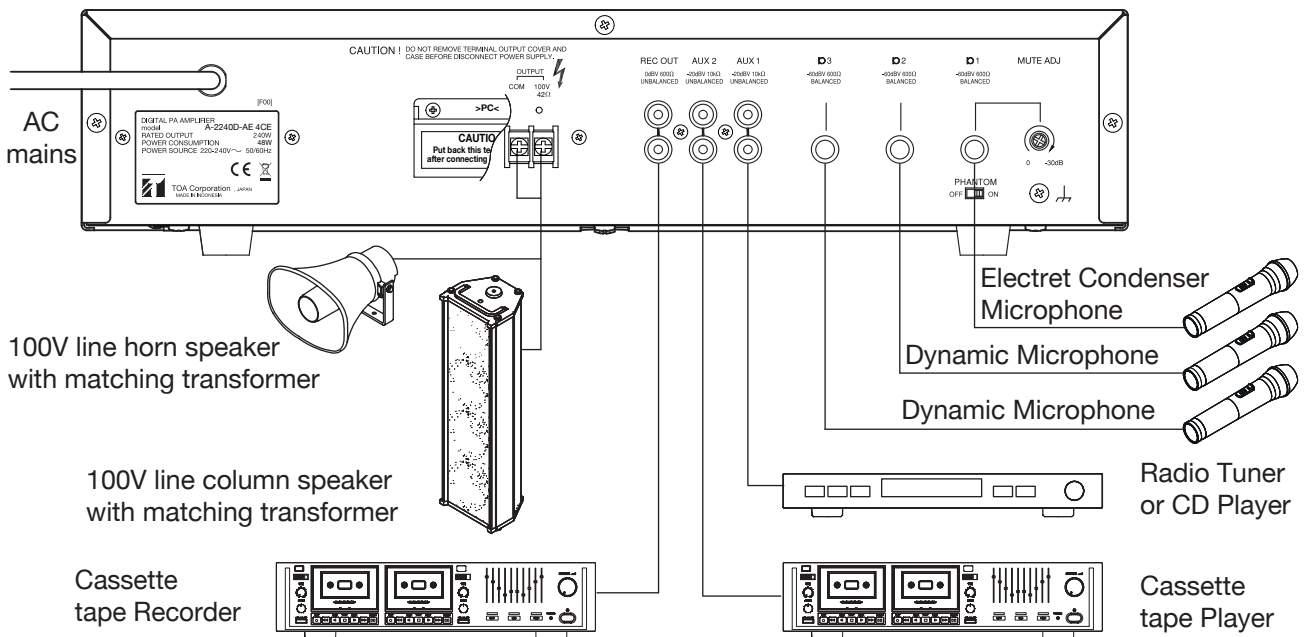

7. VOLUME CONTROL SETTING

Output levels are adjustable with individual volume control. Rotate clockwise to increase the volume level & counter clockwise to decrease it. For music play or announcement, adjust the corresponding volume control until the indicator PEAK (red) lights intermittently. Note that the sound quality is downgraded when the PEAK indicator remains lit.

Factory preset : Minimum

8. BLOCK AND LEVEL DIAGRAMS

[A-2030D Series, A-2060D Series]

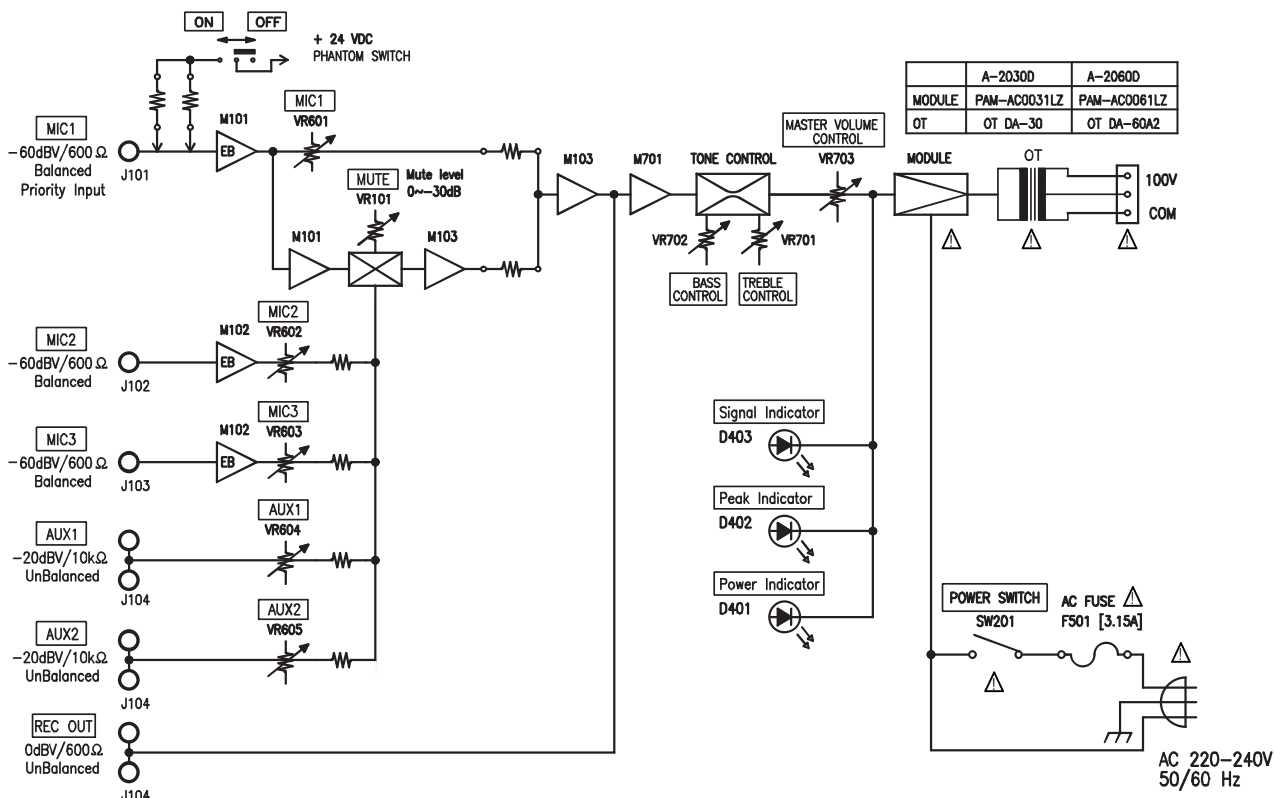

[A-2120D Series, A-2240D Series]

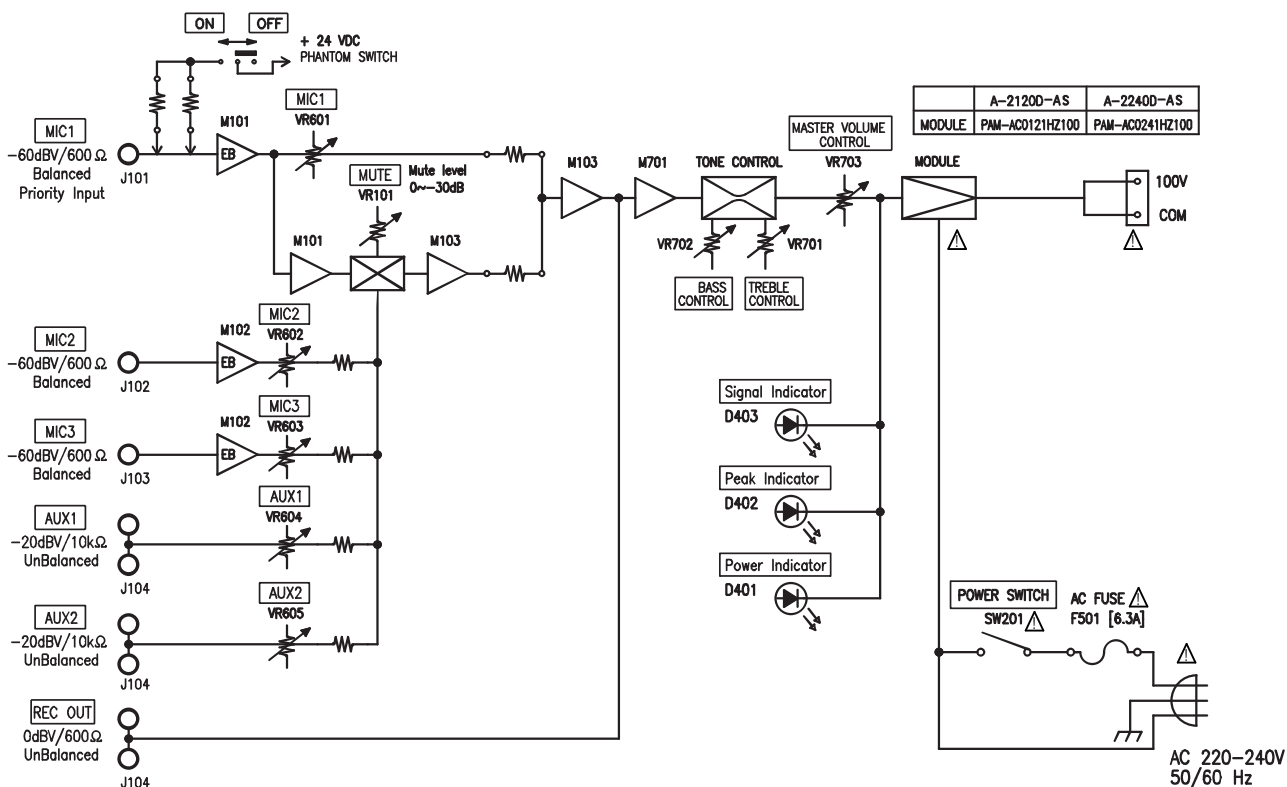

[A-2120DT-AS 2CE, A-2240DT-AS 2CE]

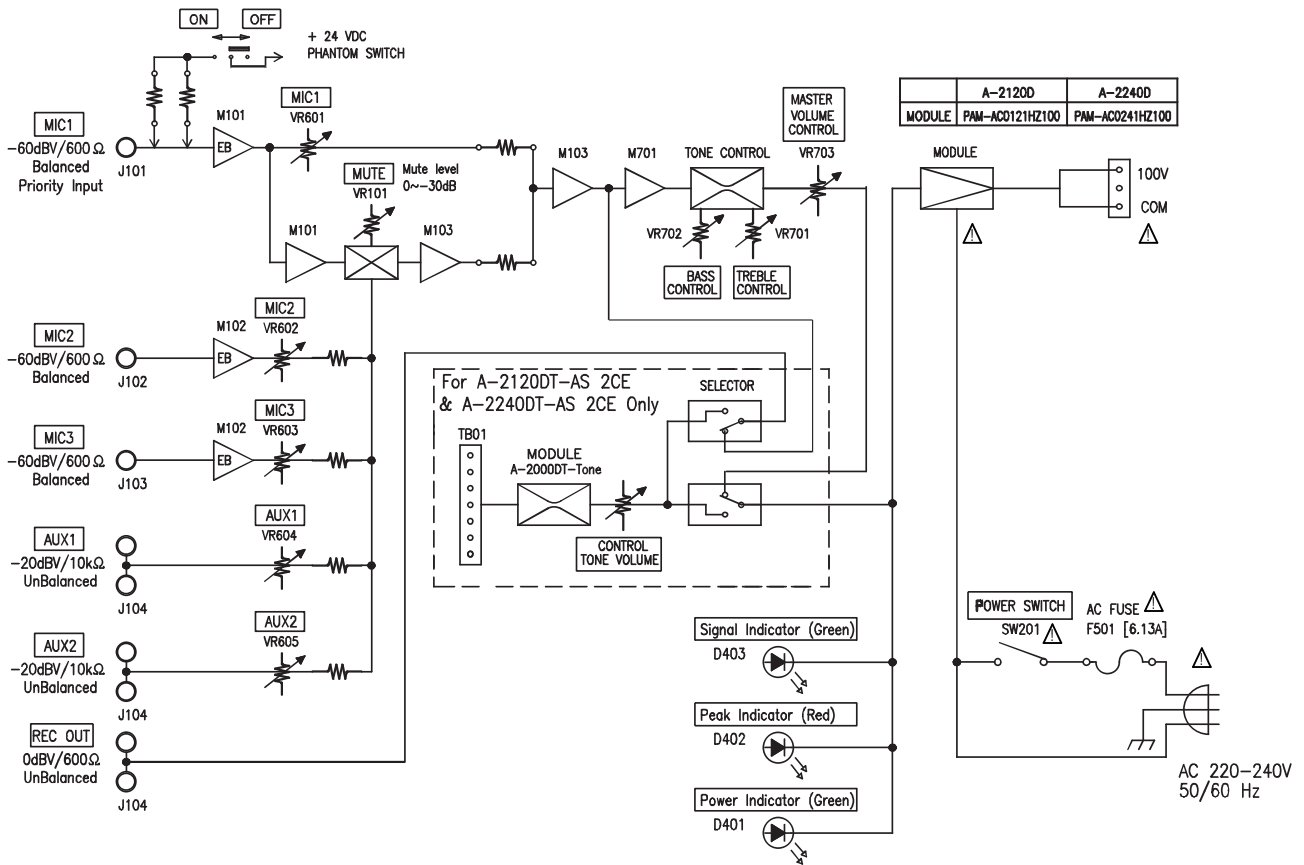

[A-2030D Series, A-2060D Series, A-2120D Series, and A-2240D Series]

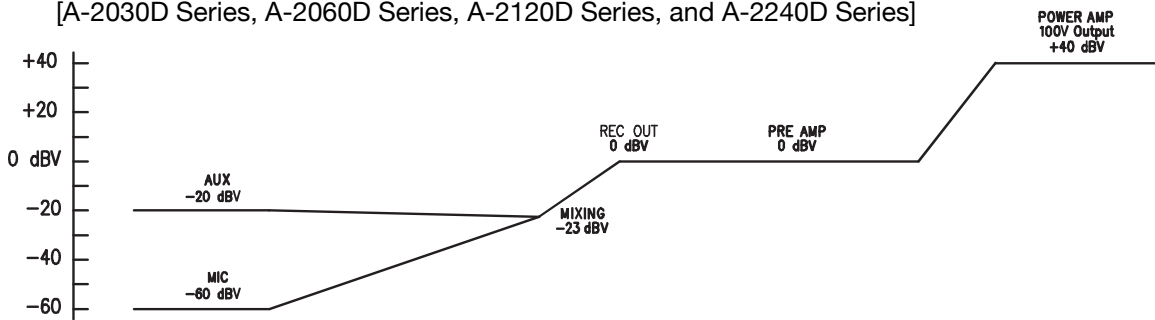

[A-2120DT-AS 2CE, A-2240DT-AS 2CE]

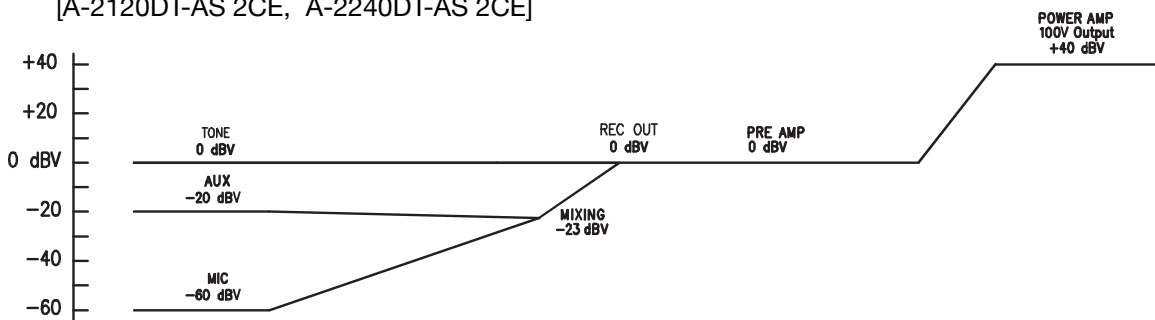

9. DIMENSIONAL DIAGRAM

Dimensional diagram represent by A-2030D-AS 2CE image. Outer dimension for all series are same.
Units : mm (inches)

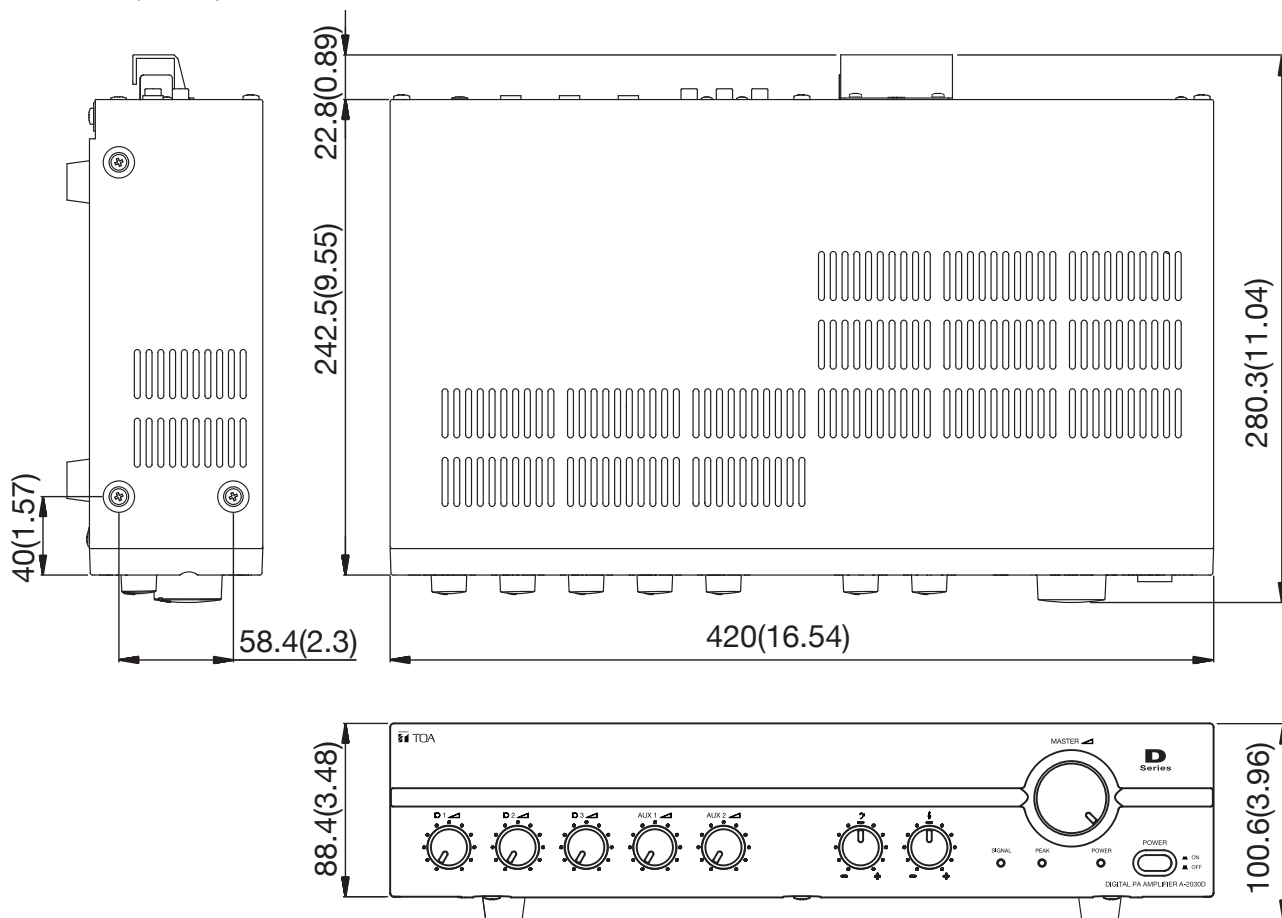

10. SPECIFICATIONS

[A-2000D-AS 2CE Series]

Model no.	A-2030D-AS	A-2060D-AS	A-2120D-AS	A-2240D-AS
Power Source	220-240V~ 50/60Hz			
Rated Output	30W	60W	120W	240W
Power Consumption (EN 60065)	12W	16W	34W	48W
Frequency Response	50-20000Hz, ±3dB			
Distortion	Less than 1% at 1kHz, 1/3 Rated Power			
Input	MIC 1-3	-60 dB (0dB=1V), 600Ω, Balanced, XLR3 -31 type		
	AUX 1-2	-20 dB (0dB=1V), 10kΩ, Unbalanced, RCA pin jack		
Output	Speaker out	Balanced (Floating)		
	Line 100V	330Ω	170Ω	83Ω
	Rec Out	0dB (1V), 600Ω, Unbalanced RCA pin jack		
Phantom Power	DC +21V (MIC 1)			
S/N Ratio	Over 60dB			
Tone Control	Bass ±10dB at 100Hz			
	Treble ±10dB at 10kHz			
Muting	MIC 1 : mute other input signal by 0-30dB attenuation			
Indicator	POWER, PEAK, SIGNAL			
Finish	Panel : ABS Resin, Black			
	Case : Steel Plate, Black			
Dimensions	420 (w) x 100.6 (h) x 280.3 (d) mm (16.54" x 3.96" x 11.04")			
Weight	4.0 kg (8.88 lb)	4.6 kg (10.14 lb)	4.0 kg (8.88 lb)	4.0 kg (8.88 lb)

*Design & specification are subject to change without notice for improvement.

[A-2000DT-AS 2CE Series]

Model no.	A-2120DT-AS		A-2240DT-AS	
Power Source	220-240V \sim 50/60Hz			
Rated Output	120W		240W	
Power Consumption (EN 60065)	34W		48W	
Frequency Response	50-20000Hz, \pm 3dB			
Distortion	Less than 1% at 1kHz, 1/3 Rated Power			
Input	MIC 1-3	-60 dB (0dB=1V), 600 Ω , Balanced, XLR3 -31 type		
	AUX 1-2	-20 dB (0dB=1V), 10k Ω , Unbalanced, RCA pin jack		
	TONES	6 Tone contact trigger (chime, Bell, Evac, Alert, Lockdown, Clear) will be mute the other function		
Output	Speaker out	Balanced (Floating)		
	Line 100V	83 Ω	42 Ω	
	Rec Out	0dB (1V), 600 Ω , Unbalanced RCA pin jack		
Phantom Power	DC +21V (MIC 1)			
S/N Ratio	Over 60dB			
Tone Control	Bass \pm 10dB at 100Hz			
	Treble \pm 10dB at 10kHz			
Muting	MIC 1 : mute other input signal by 0-30dB attenuation			
Indicator	POWER, PEAK, SIGNAL			
Finish	Panel : ABS Resin, Black			
	Case : Steel Plate, Black			
Dimensions	420 (w) x 100.6 (h) x 280.3 (d) mm (16.54" x 3.96" x 11.04")			
Weight	4.0 kg (8.88 lb)		4.0 kg (8.88 lb)	

*Design & specification are subject to change without notice for improvement.

[A-2000DD-EB 1CE Series, A-2000DD-EB 4CE Series]

Model no.	A-2030DD-EB	A-2060DD-EB	A-2120DD-EB	A-2240DD-EB
Power Source	220-240V \sim 50/60Hz			
Rated Output	30W	60W	120W	240W
Power Consumption (EN 60065)	12W	16W	34W	48W
Frequency Response	50-20000Hz, \pm 3dB			
Distortion	Less than 1% at 1kHz, 1/3 Rated Power			
Input	MIC 1	-60 dB (0dB=1V), 600 Ω , Balanced, 5-P DIN type		
	MIC 2-3	-60 dB (0dB=1V), 600 Ω , Balanced, Phone jack		
	AUX 1-2	-20 dB (0dB=1V), 10k Ω , Unbalanced, RCA pin jack		
	Mute	Mute : contact pin 4-5 closure to input (for MIC1)		
Output	Speaker out	Balanced (Floating)		
	Line 100V	330 Ω	170 Ω	83 Ω 42 Ω
	Rec Out	0dB (1V), 600 Ω , Unbalanced RCA pin jack		
Phantom Power	DC +21V (MIC 1)			
S/N Ratio	Over 60dB			
Tone Control	Bass \pm 10dB at 100Hz			
	Treble \pm 10dB at 10kHz			
Muting	MIC 1 : mute other input signal by 0-30dB attenuation			
Indicator	POWER, PEAK, SIGNAL			
Finish	Panel : ABS Resin, Black			
	Case : Steel Plate, Black			
Dimensions	420 (w) x 100.6 (h) x 280.3 (d) mm (16.54" x 3.96" x 11.04")			
Weight	4.0 kg (8.88 lb)	4.6 kg (10.14 lb)	4.0 kg (8.88 lb)	4.0 kg (8.88 lb)

*Design & specification are subject to change without notice for improvement.

[A-2000D-EA 4CE Series, A-2000D-EB 1CE Series, A-2000D-EB 4CE Series]

Model no.	A-2030D-EA, A-2030D-EB	A-2060D-EA, A-2060D-EB	A-2120D-EA, A-2120D-EB	A-2240D-EA, A-2240D-EB
Power Source	220-240V \sim 50/60Hz			
Rated Output	30W	60W	120W	240W
Power Consumption (EN 60065)	12W	16W	34W	48W
Frequency Response	50-20000Hz, \pm 3dB			
Distortion	Less than 1% at 1kHz, 1/3 Rated Power			
Input	MIC 1-3	-60 dB (0dB=1V), 600 Ω , Balanced, Phone jack		
	AUX 1-2	-20 dB (0dB=1V), 10k Ω , Unbalanced, RCA pin jack		
Output	Speaker out	Balanced (Floating)		
	Line 100V	330 Ω	170 Ω	83 Ω 42 Ω
	Rec Out	0dB (1V), 600 Ω , Unbalanced RCA pin jack		
Phantom Power	DC +21V (MIC 1)			
S/N Ratio	Over 60dB			
Tone Control	Bass \pm 10dB at 100Hz			
	Treble \pm 10dB at 10kHz			
Muting	MIC 1 : mute other input signal by 0-30dB attenuation			
Indicator	POWER, PEAK, SIGNAL			
Finish	Panel : ABS Resin, Black			
	Case : Steel Plate, Black			
Dimensions	420 (w) x 100.6 (h) x 280.3 (d) mm (16.54" x 3.96" x 11.04")			
Weight	4.0 kg (8.88 lb)	4.6 kg (10.14 lb)	4.0 kg (8.88 lb)	4.0 kg (8.88 lb)

*Design & specification are subject to change without notice for improvement.

Traceability Information for Europe

Manufacturer:

PT. TOA GALVA INDUSTRIES
 Jl. Raya Jakarta Bogor Km. 34-35 Sukamaju Baru, Tapos 16958
 Kota Depok - Indonesia

Authorized representative:

TOA Electronics Europe GmbH
 Suederstrasse 282, 20537 Hamburg,
 Germany